



## Sun Cap Installation Instructions

**For: Wrangler 1986 - 1991**

**Part Number: 41504**

**Important Note:** If your vehicle has not been fitted with a factory soft top or has snaps on the windshield, it will be necessary to purchase a Windshield Channel Kit Number 45809-01 from your local distributor.

### **WARNING**

This product is designed to enhance the appearance of the vehicle and to shield the occupants from ordinary weather conditions. Do not rely in any way on the components of this product to contain occupants within the vehicle, or to protect against injury or death in the event of an accident. This top will not protect the occupants from falling objects. Never operate vehicle in excess of manufacturer's specifications.

**WEAR SEAT BELTS AT ALL TIMES**

Read and follow, precisely, all installation instructions provided when installing top. Failure to do so may result in a poor fitting top and could place occupants of the vehicle in a potentially dangerous situation. After installing or reinstalling the top, check to make sure it has been properly installed.

### **Installation Tips**

*After completing the installation, keep these instructions for future reference. Before you begin installing this product, read all instructions thoroughly. Below are a few tips to make this installation easier.*

#### **For a smooth fit:**

For ease in installation, this product should be installed at temperatures above 72° F. Below this temperature, the fabric may contract an inch or more, making it difficult to fit to the vehicle.

It is normal for the fabric to contract and wrinkle when stored in the shipping carton. Within a few days after the installation, the fabric will relax and the wrinkles will disappear.

## Step One

Locate the Sun Cap and orient it on the vehicle. Drape it over the sport bar and insert the front of the Sun Cap into the windshield channel.

**Note: If your vehicle has snaps on the windshield, it will be necessary to remove them and install a Windshield Retainer Kit number 45809-01.**

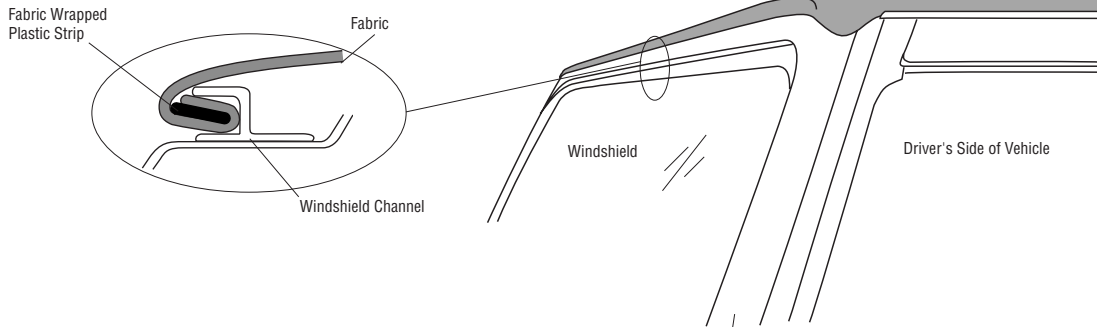

## Step Two

Pull the Sun Cap back over the sport bar. Loop the two web straps under the sport bars and thread them through the buckles, sewn to the straps.

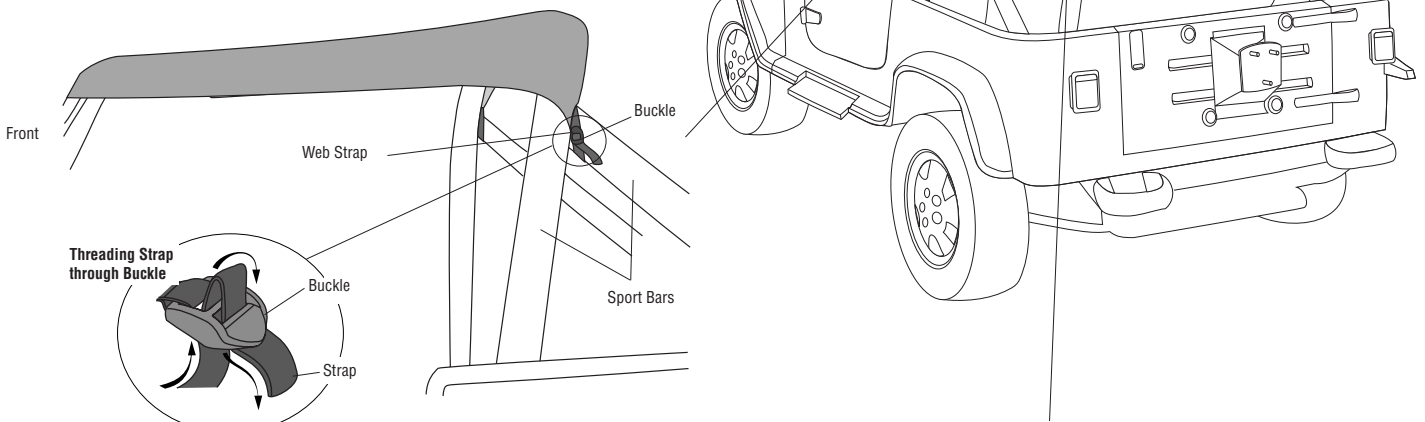

## Step Three

Locate the long web strap sewn to the rear of the top. Wrap the strap around the sport bar and pull it toward the front of the top. Thread it through the footman loop located above the windshield. Pull the end of the strap back and thread it through the buckle on the strap. Pull the strap tight.

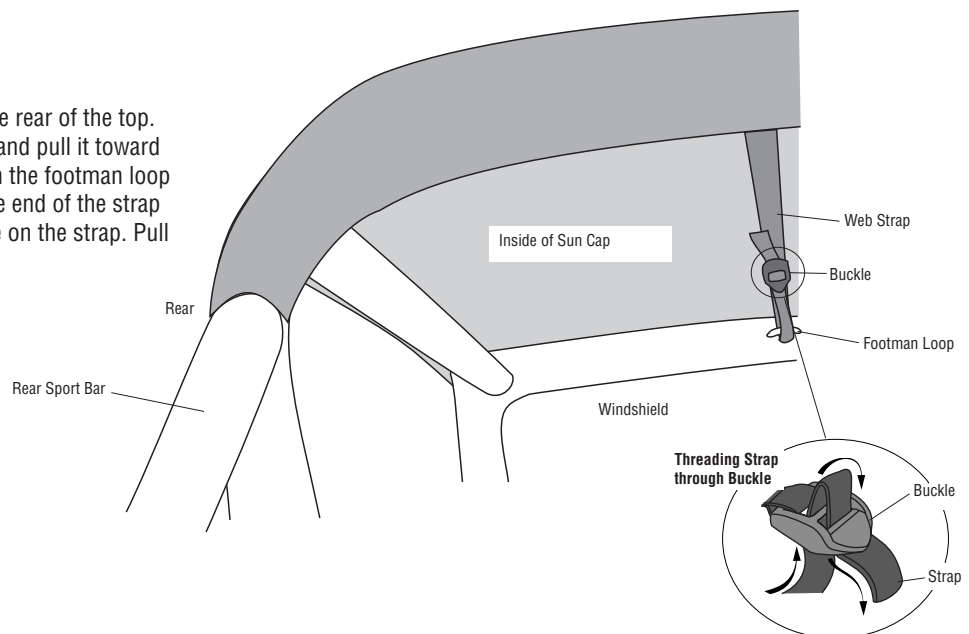

### **LIMITED WARRANTY**

We warrant our product to be free from defects in material and workmanship, for the terms specified below, provided there has been normal use and proper maintenance. This warranty applies to the original purchaser only. All remedies under this warranty are limited to the repair or replacement of any item or items found by the factory to be defective within the time period specified.

If you have a warranty claim, first you must call our factory at the number below for instructions. You must retain proof of purchase and submit a copy with any items returned for warranty work. Upon completion of warranty work, if any, we will return the repaired or replaced item or items to you freight prepaid. Damage to our products caused by accidents, fire, vandalism, negligence, misinstallation, misuse, Acts of God, or by defective parts not manufactured by us, is not covered under this warranty.

THE WARRANTY TIME PERIOD IS AS FOLLOWS: ALL "SOFT GOODS" MANUFACTURED BY OUR COMPANY (USING PRIMARILY VINYL, PLASTICS, AND/OR FOAM): ONE YEAR FROM DATE OF PURCHASE.

ANY IMPLIED WARRANTIES OF MERCHANTABILITY AND/OR FITNESS FOR A PARTICULAR PURPOSE CREATED HEREBY ARE LIMITED IN DURATION TO THE SAME DURATION AND SCOPE AS THE EXPRESS WRITTEN WARRANTY. OUR COMPANY SHALL NOT BE LIABLE FOR ANY INCIDENTAL OR CONSEQUENTIAL DAMAGE.

Some states do not allow limitations on how long an implied warranty lasts, or the exclusion or limitation of incidental or consequential damages, so the above limitations or exclusions may not apply to you.

This warranty gives you specific legal rights, and you may also have other rights which vary from state to state.

For further information or request for warranty work, please contact: Customer Service  
877-638-9509